

VESA 100x100 to 600x400mm

- 154 lbs Max Total Weight Bearing
- Middle Shelf Adjustable from 5" to 27" from Base & Includes a Tie Down Strap
- Top Camera or Small Component Shelf Can Be Adjusted from 5" to 15½" from Top of Main Post
- Main Post Adjustable from 40" to 60½" from Base
- Durable Steel Construction with Powder Coated Black Finish for a Sleek Presentation
- Cable Management
- 4 Lockable Security Wheels
- Packed in 1 Box

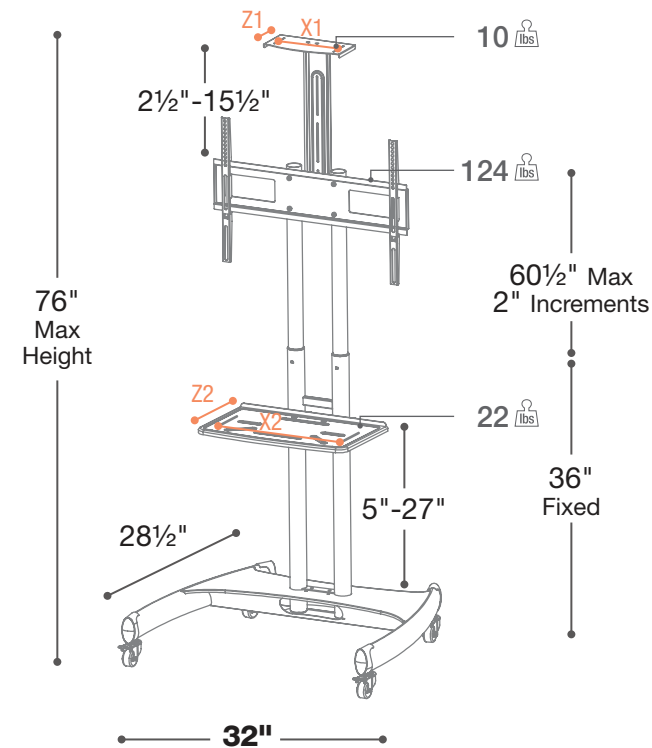

- X1 = 10" Usable Shelf Width
- Z1 = 5" Usable Shelf Depth
- X2 = 19¾" Usable Shelf Width
- Z2 = 12" Usable Shelf Depth

Frame

N

Black

Shelf

D

Dark Glass